

DC/DC Converter

PN1-XXSXXA3NT Series

Typical Feature

- ◆ Fixed Input Voltage, isolated & unregulated Output, power 1W
- ◆ Continuous short circuit protection
- ◆ Operating Temperature: -40°C to +105°C
- ◆ Small SMD package, international standard pin out
- ◆ Isolation Voltage 3000VDC
- ◆ High efficiency up to 88%
- ◆ No load input current as low as 5mA
- ◆ ESD satisfy 8KV contact discharge



Application Filed

PN1-XXSXXA3NT is suitable for pure digital systems, low frequency analog circuits, relay-driven circuits. It is specially designed for applications where an isolated voltage is required in a distributed power supply system.

It could be widely used in the below products:

1. The voltage of the input power supply is relatively stable(voltage change range:±10%Vin)
2. Isolation between input and output is required (Isolation Voltage≤3000VDC);
3. Low requirements for output voltage stability and output ripple noise;

Typical Product List

Part No	Input Voltage	Output Voltage/Current		Max. Capacitive Load (MAX)	Ripple & Noise 20MHz (TYP/MAX)	Efficiency (MIN/TYP)
	(VDC)	Voltage	Current			
	Range	(VDC)	(mA) MAX / MIN	u F	mVp-p	%
PN1-3V3S3V3A3NT	3.3 (2.97-3.63)	3.3	303/30	2400	50/100	74/76
PN1-3V3S05A3NT		5	200/20	2400	50/100	80/82
PN1-3V3S09A3NT		9	111/11	1000	50/100	83/85
PN1-3V3S12A3NT		12	83/8	560	100/150	85/87
PN1-3V3S15A3NT		15	67/7	560	100/150	85/87
PN1-3V3S24A3NT		24	42/4	220	100/150	83/85
PN1-05S3V3A3NT	5 (4.5-5.5)	3.3	303/30	2400	50/100	78/80
PN1-05S05A3NT		5	200/20	2400	50/100	83/85
PN1-05S09A3NT		9	111/11	1000	50/100	84/86
PN1-05S12A3NT		12	83/8	1000	100/150	85/87
PN1-05S15A3NT		15	67/7	560	100/150	85/87
PN1-05S24A3NT		24	42/4	220	100/150	86/88
PN1-12S3V3A3NT	12 (10.8-13.2)	3.3	303/30	2400	50/100	80/82
PN1-12S05A3NT		5	200/20	2400	50/100	84/86
PN1-12S12A3NT		12	83/8	1000	50/100	84/86
PN1-12S15A3NT		15	67/6	560	50/100	84/86
PN1-12S24A3NT		24	42/4	220	50/100	84/86

DC/DC Converter

PN1-XXSXXA3NT Series

PN1-15S05A3NT	15 (13.5-16.5)	5	200/20	2400	50/100	84/86
PN1-24S05A3NT	24 (21.6-26.4)	5	200/20	2400	50/100	84/86
PN1-24S12A3NT		12	83/8	1000	50/100	84/86
PN1-24S15A3NT		15	67/6	560	50/100	84/86

Note 1: The typical output efficiency is based on that product is full loaded and burned-in after half an hour.

Note 2: The fluctuation range of full load efficiency(% ,TYP) is $\pm 2\%$, full load output efficiency= total output power/module's input power.

Note 3: Ripple & Noise Tested by twisted-pair method, for details please check Ripple& Noise Test Method.

Input Specifications

Item	Operating Condition		Min.	Typ.	Max.	Unit
Input Current (Full load/ No load)	3.3Vdc Input	3.3Vdc/ 5Vdc output	-	370/5	380/20	mA
		9Vdc output	-	357/5	365/20	
		12Vdc/ 15Vdc output	-	348/10	357/20	
		24Vdc output	-	357/20	365/30	
	5Vdc Input	3.3Vdc output	-	244/5	250/20	
		5Vdc/ 9Vdc output	-	233/6	238/20	
		12Vdc/ 15Vdc output	-	225/15	230/25	
		24Vdc output	-	244/30	250/40	
	12Vdc Input	3.3Vdc output	-	96/3	104/15	
		5Vdc output	-	196/2	198/15	
		12Vdc output	-	89/3	91/15	
		15Vdc output	-	93/7	95/15	
	15Vdc Input	5Vdc output	-	98/7	103/15	
	24Vdc Input	5Vdc output	-	78/5	82/20	
		12Vdc output	-	47/3	50/8	
		15Vdc output	-	48/5	50/8	
Reflected Ripple Current	-		-	15	-	
Overshoot Voltage	3.3V Input		-0.7	-	9	VDC
	5Vdc Input		-0.7	-	11	
	12Vdc Input		-0.7	-	18	
	15Vdc Input		-0.7	-	21	
	24Vdc Input		-0.7	-	30	
Overshoot Current	-		-	0.8	-	A
Input Filter Type	Capacitor Filter					

DC/DC Converter

PN1-XXSXXA3NT Series

Hot Plug		Unavailable				
Output Specifications						
Item	Operating Condition		Min.	Typ.	Max.	Unit
Output Voltage Accuracy	-		See Regulation Curve			
Line Regulation	Input voltage change $\pm 1\%$	3.3Vdc/ 5Vdc output	-	-	± 1.5	%
		Other Voltage output	-	-	± 1.2	
Load Regulation	10%-100% load	3.3Vdc/ 5Vdc output	-	10	15	%
		Other Voltage output	-	8	10	
Temperature Drift Coefficient	Full load		-	-	± 0.03	%/°C
Short Circuit Protection	-		Continuous, Self-recovery			
General Specifications						
Item	Operating Condition		Min.	Typ.	Max.	Unit
Insulation Withstand Voltage	Input-output, Test 1min, leakage current $\leq 0.5\text{mA}$		3000	-	-	VDC
Insulation Resistance	Input-output, Insulation Voltage 500VDC		1000	-	-	M Ω
Isolation Capacitor	Input-output, 100KHz/0.1V		-	20	-	PF
Operating Temperature	Temperature $\geq 105^\circ\text{C}$, see Temperature Derating Curve		-40	-	105	°C
Case Temperature Rise	Ambient Temperature 25°C		-	15	-	
Storage Temperature	-		-55	-	135	
Reflow Temperature	Peak temperature $T_c \leq 250^\circ\text{C}$, the maxi time is 60S for temp above 217°C					
Storage Humidity	No condensing		-	-	95	%RH
Switching Frequency	Full load	3.3Vdc/5Vdc Input	-	260	-	KHz
		12Vdc/15Vdc/24Vdc Input	-	450	-	
MTBF	MIL-HDBK-217F@ 25°C		3000			K hours
Material Characteristics						
Case Material		Black flame-retardant heat-resistant plastic (UL94 V-0)				
Packing Dimension	SMD package	12.7X11.20X7.25 mm				
Product Weight		1.4g(TYP.)				
Cooling Method		Natural air cooling				
EMC Character						
EMI	CE	CISPR32/EN55032 CLASS B (See EMC recommended circuit)				
	RE	CISPR32/EN55032 CLASS B (See EMC recommended circuit)				
EMS	ESD	IEC/EN61000-4-2 Air $\pm 8\text{kV}$, Contact $\pm 8\text{kV}$ perf. Criteria B				

Product Character Curve

Output Regulation Curve

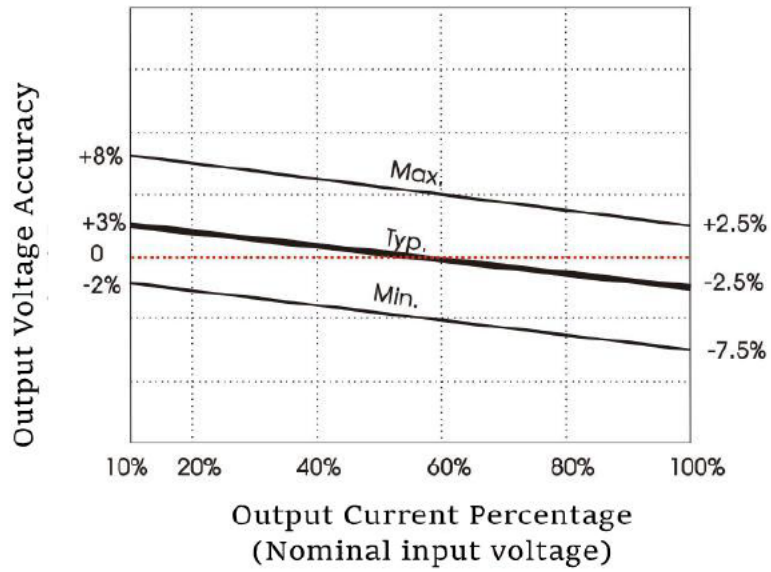

Products Characteristic Curve

Temperature Derating Curve

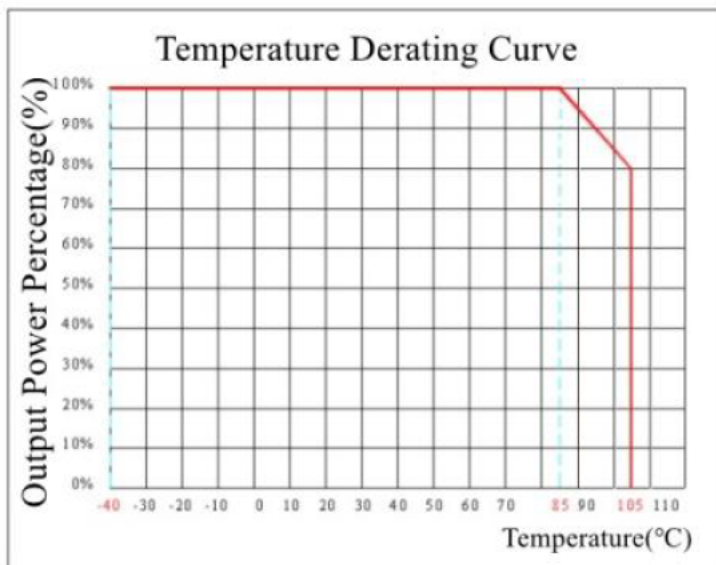

Application Circuit

1. Typical Application

In order to ensure the input/output ripple and noise decreased, capacitor filter net could be connected to input and output side, application circuit as below photo 3; choosing suitable filter capacitor is very important, start-up problems may be caused by too large capacitance.

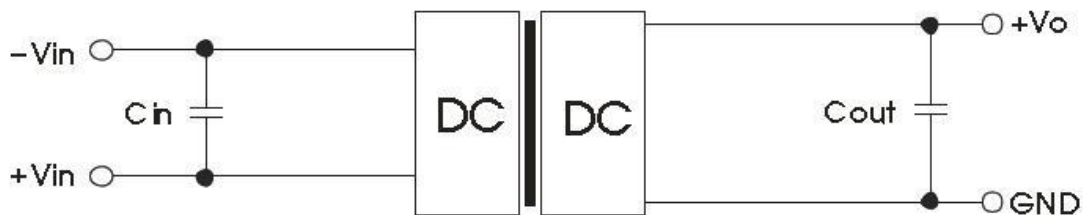

Note 1: Cin is 4.7uF/50V, Cout is 10uF/50V

2. EMC Typical Recommended Circuit

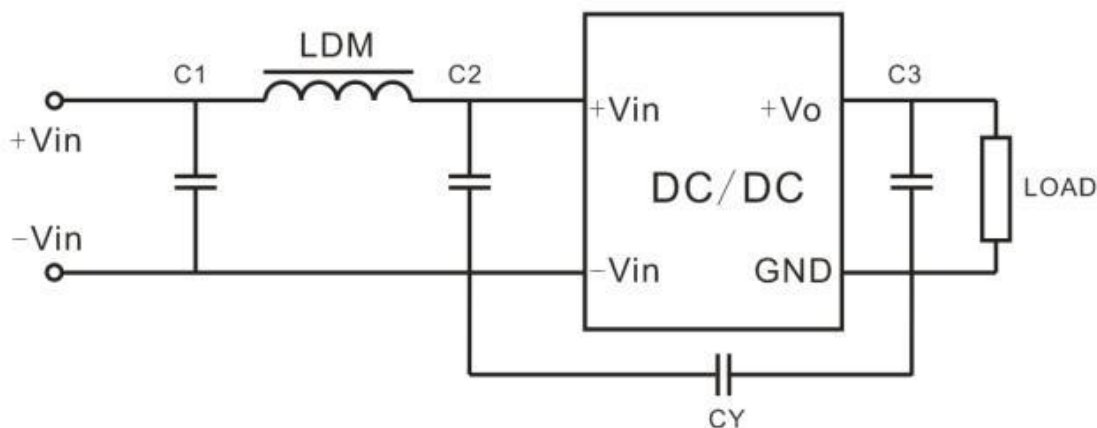

Note 2: C1,C2 are 4.7uF/50V, LDM is 6.8uH, CY is 1nF/250Vac, for C3, please refer to the Typical Circuit.

3. Ripple & Noise Test: (Twisted Pair Method 20MHZ bandwidth)

- a. 12# twisted pair to connect, Oscilloscope bandwidth set as 20MHz, 100M bandwidth probe, terminated with 0.1uF polypropylene capacitor and 4.7uF high frequency low resistance electrolytic capacitor in parallel, oscilloscope set as Sample pattern.
- b. Input terminal connect to power supply, output terminal connect to electronic load through jig plate, Use 30cm±2 cm sampling line, Power line selected from corresponding diameter wire with insulation according to the flow of output current.

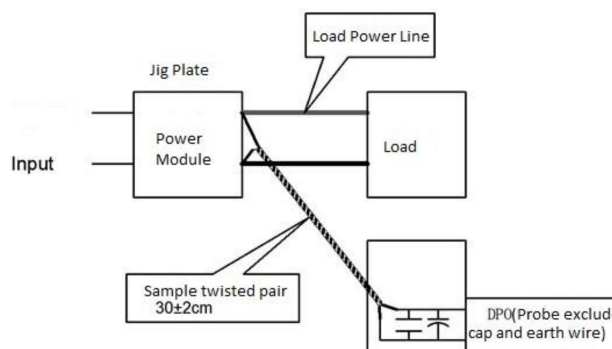

4. Output load requirement

In order to ensure the converter can work reliably with high efficiency, the minimum load should not less than 10% rated load when it is used. If the needed power is indeed small, please parallel a resistor at the output side. (The actual using power and the power of the resistor should be more than 10% rated power)

THIRD ANGLE PROJECTION 

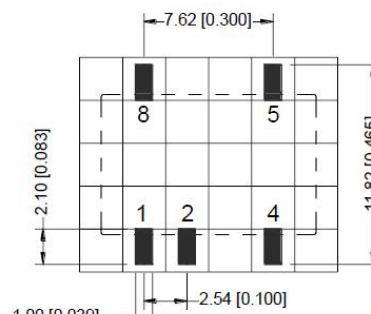
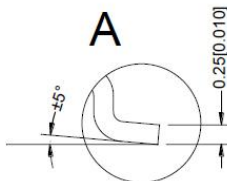
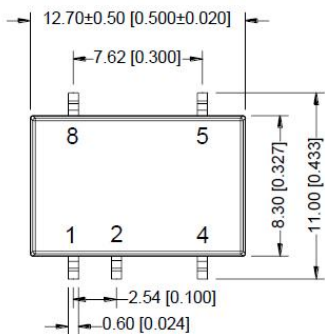

Note: Grid: 2.54*2.54mm

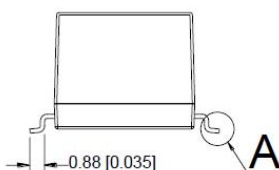
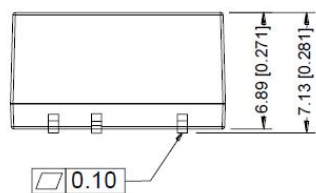

Pin-out	
Pin	Mark
1	-Vin
2	+Vin
4	GND
5	+Vo
8	NC

NC: Pin to be isolated from circuitry

Note:
 Unit:mm[inch]
 Pin section tolerances: $\pm 0.10\text{mm}[\pm 0.004\text{ inch}]$
 General tolerances: $\pm 0.25\text{mm}[\pm 0.010\text{inch}]$

Note: if the definition of pin is not in accordance with the model selection manual, please refer to the label on actual item.

Packing Information

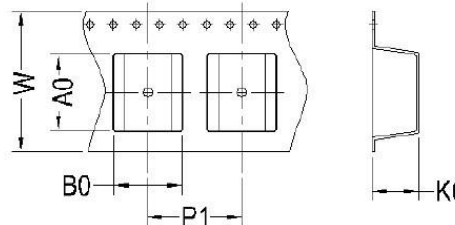
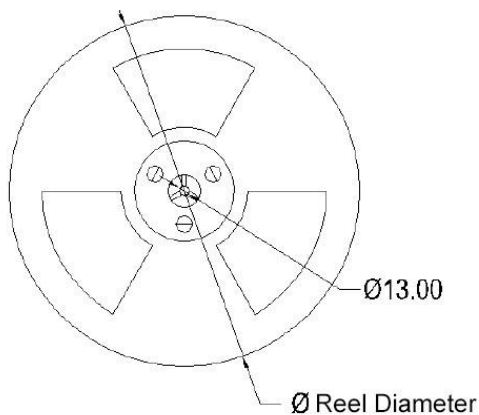

Quadrant assignments for Pin 1 orientation in tape

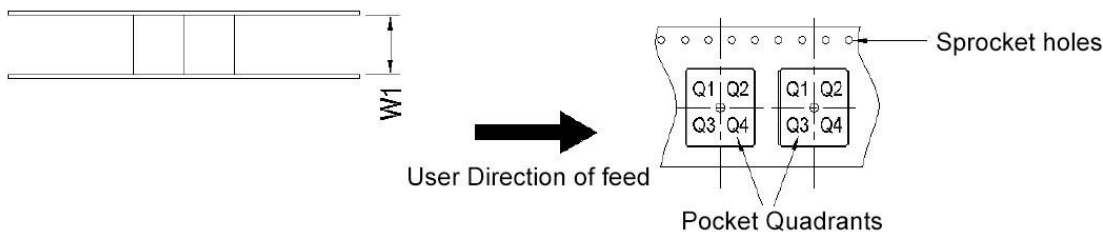

Components	Package	PIN	SPQ	Reel diameter(mm)	Reel width(mm)	A0 (mm)	B0 (mm)	K0(mm)	P1(mm)	W (mm)	PIN Quadrant
PN1-XXSXXA3NT	SMD	5	500	330	24.5	13.1	11.7	7.5	16.0	24	Q1

Note:

1. If the product is operated under the min. required load, the product performance cannot be guaranteed to comply with all performance indexes in this datasheet;
2. The maximum capacitive load is tested under nominal input voltage range and full load condition;
3. Unless otherwise specified, data in this datasheet are tested under conditions of **Ta=25°C**, **humidity<75%** when inputting nominal voltage and outputting rated load(pure resistance load);
4. All index testing methods in this datasheet are based on our Company's corporate standards.
5. We can provide customized product service;